

Series : QQDRR/4



SET-2

प्रश्न-पत्र कोड 31/4/2
Q.P. Code

रोल नं.

Roll No.

--	--	--	--	--	--	--	--

परीक्षार्थी प्रश्न-पत्र कोड को उत्तर-पुस्तिका के मुख-पृष्ठ पर अवश्य लिखें ।

Candidates must write the Q.P. Code on the title page of the answer-book.

- कृपया जाँच कर लें कि इस प्रश्न-पत्र में मुद्रित पृष्ठ 16 हैं ।
- प्रश्न-पत्र में दाहिने हाथ की ओर दिए गए प्रश्न-पत्र कोड को छात्र उत्तर-पुस्तिका के मुख-पृष्ठ पर लिखें ।
- कृपया जाँच कर लें कि इस प्रश्न-पत्र में 15 प्रश्न हैं ।
- कृपया प्रश्न का उत्तर लिखना शुरू करने से पहले, उत्तर-पुस्तिका में प्रश्न का क्रमांक अवश्य लिखें ।
- इस प्रश्न-पत्र को पढ़ने के लिए 15 मिनट का समय दिया गया है । प्रश्न-पत्र का वितरण पूर्वाह्न में 10.15 बजे किया जाएगा । 10.15 बजे से 10.30 बजे तक छात्र केवल प्रश्न-पत्र को पढ़ेंगे और इस अवधि के दौरान वे उत्तर-पुस्तिका पर कोई उत्तर नहीं लिखेंगे ।
- Please check that this question paper contains 16 printed pages.
- Q.P. Code given on the right hand side of the question paper should be written on the title page of the answer-book by the candidate.
- Please check that this question paper contains 15 questions.
- **Please write down the Serial Number of the question in the answer-book before attempting it.**
- 15 minute time has been allotted to read this question paper. The question paper will be distributed at 10.15 a.m. From 10.15 a.m. to 10.30 a.m., the candidates will read the question paper only and will not write any answer on the answer-book during this period. *

विज्ञान SCIENCE

निर्धारित समय : 2 घण्टे

Time allowed : 2 hours

अधिकतम अंक : 40

Maximum Marks : 40

31/4/2

136 B

1

P.T.O.

सामान्य निर्देश :

निम्नलिखित निर्देशों को बहुत सावधानी से पढ़िए और उनका सख्ती से पालन कीजिए :

- (i) इस प्रश्न-पत्र में कुल 15 प्रश्न हैं। सभी प्रश्न अनिवार्य हैं।
- (ii) यह प्रश्न-पत्र तीन खण्डों में विभाजित है – खण्ड-क, ख एवं ग।
- (iii) खण्ड-क : प्रश्न संख्या 1 से 7 लघु-उत्तरीय प्रकार के प्रश्न हैं। प्रत्येक प्रश्न 2 अंक का है।
- (iv) खण्ड-ख : प्रश्न संख्या 8 से 13 भी लघु-उत्तरीय प्रकार के प्रश्न हैं। प्रत्येक प्रश्न 3 अंक का है।
- (v) खण्ड-ग : प्रश्न संख्या 14 और 15 प्रकरण आधारित प्रश्न हैं। प्रत्येक प्रश्न 4 अंक का है।
- (vi) कुछ प्रश्नों में आंतरिक चयन प्रदान किया गया है। इस प्रकार के प्रश्नों में केवल एक ही विकल्प का उत्तर दीजिए।

*

खण्ड – क

1. मानव के मादा जनन तंत्र में (a) प्लैसेन्टा (b) फैलोपियन ट्यूब (c) गर्भाशय और (d) अंडाशय के कार्य का उल्लेख कीजिए। 2
2. पौधे की ऊँचाई (लम्बापन / बौनापन) के उदाहरण का उपयोग करके यह दर्शाइए कि जीव में जीन लक्षणों को नियंत्रित करते हैं। 2

अथवा

किसी लाल रंग के पुष्पों और सफेद रंग के पुष्पों के संकरण में जब F₁ संतति के लाल रंग के पुष्पों वाले पौधों का स्वपरागण कराया गया तो F₂ संतति में प्राप्त पौधों में 75% पौधे लाल पुष्पों वाले तथा 25% पौधे सफेद पुष्पों वाले थे। उपरोक्त प्रकरण में लक्षणों की वंशानुगति की केवल प्रवाह आरेख खींचकर तथा प्राप्त होने वाले पौधों के अनुपात सहित व्याख्या कीजिए।

31/4/2

2



General Instructions :

Read the following instructions carefully and strictly follow them :

- (i) This question paper contains **15** questions. **All** questions are compulsory.
- (ii) This question paper is divided into **three** Sections viz. Section **A**, **B** and **C**.
- (iii) Section **A** - Question numbers **1** to **7** are short answer type questions. Each question carries **two** marks.
- (iv) Section **B** - Question numbers **8** to **13** are also short answer type questions. Each question carries **three** marks.
- (v) Section **C** – Question No. **14** and **15** are case based questions. Each question carries **four** marks.
- (vi) Internal choices have been provided in some questions. Only one of the alternatives has to be attempted.

SECTION – A

1. Mention the functions of (a) Placenta (b) Fallopian tubes (c) Uterus and (d) Ovary in the human female reproductive system. **2**

2. Using height (tallness / dwarfness) of a plant as an example, show that genes control the characteristics or traits in an organism. **2**

OR

In a cross between red coloured and white coloured flowers, when plants with red coloured flowers of F1 generation were self pollinated, plants of F2 generation were obtained in which 75% of plants were with red flowers and 25% plants were with white flowers.

Explain the inheritance of traits in the above cross with the help of a flow chart only along with the ratio of plants obtained.

31/4/2

3



P.T.O.



3. नीचे दिए गए कार्बन के यौगिकों के आण्विक सूत्रों पर विचार कीजिए : 2

(i) CH_3COOH (ii) CH_3OH (iii) C_2H_6 (iv) C_3H_4 (v) C_4H_8

(a) इनमें से कौन सा यौगिक एल्कोहॉलों की समजातीय श्रेणी से संबंधित है ?

(b) उस यौगिक की पहचान कीजिए जिसके दो कार्बन अणुओं के बीच त्रिआबन्ध है ।

(c) उस समजातीय श्रेणी के पहले सदस्य का आण्विक सूत्र लिखिए जिसका CH_3COOH एक सदस्य है ।

(d) उस श्रेणी का सामान्य सूत्र लिखिए जिससे C_4H_8 संबंधित है ।

4. “हमारी जीवन शैली में सुधार से उत्पादित अपशिष्ट पदार्थों (कचरे) की मात्रा अत्यधिक हो गयी है ।” इस कथन की पुष्टि के लिए दो कारण दीजिए । 2

अथवा

“पैकेजिंग के तरीकों में बदलाव से अजैव निम्नीकरणीय वस्तुओं के कचरे में पर्याप्त वृद्धि हुई है ।” दैनिक जीवन से दो उदाहरण देकर इस कथन की पुष्टि कीजिए ।

5. पुनर्जनन (पुनरुद्भवन) किसे कहते हैं ? प्लैनेरिया में पुनर्जनन की प्रक्रिया की व्याख्या कीजिए । 2

6. आरेख में दर्शाए अनुसार एल्युमिनियम की किसी छड़ 'AB' को किसी नाल चुम्बक के दोनों ध्रुवों के बीच इस प्रकार निलम्बित किया गया है कि छड़ का अक्ष क्षैतिजतः तथा चुम्बकीय क्षेत्र की दिशा ऊर्ध्वाधर उपरिमुखी हो । छड़ को श्रेणी में एक बैटरी और एक कुंजी से संयोजित किया गया है । 2

31/4/2

4



3. Consider the following molecular formulae of carbon compounds : 2

(i) CH_3COOH (ii) CH_3OH (iii) C_2H_6 (iv) C_3H_4 (v) C_4H_8

(a) Which one of these compounds belongs to homologous series of alcohols ?

(b) Identify the compound having triple bond between carbon – carbon atoms.

(c) Write the molecular formula of the first member of the homologous series to which CH_3COOH belongs.

(d) Write the general formula of the series to which the compound C_4H_8 belongs.

4. “The improvement in our lifestyle has led to the generation of large amount of waste material.” List two reasons to justify this statement. 2

OR

“The change in packaging has resulted in waste becoming non-biodegradable.”

Giving two examples from daily life, justify this statement.

5. What is Regeneration ? Explain the process of regeneration in Planaria. 2

6. As shown in the diagram an aluminium rod ‘AB’ is suspended horizontally between the two poles of a strong horse shoe magnet in such a way that the axis of rod is horizontal and the direction of the magnetic field is vertically upward. The rod is connected in series with a battery and a key. 2

31/4/2

5



P.T.O.



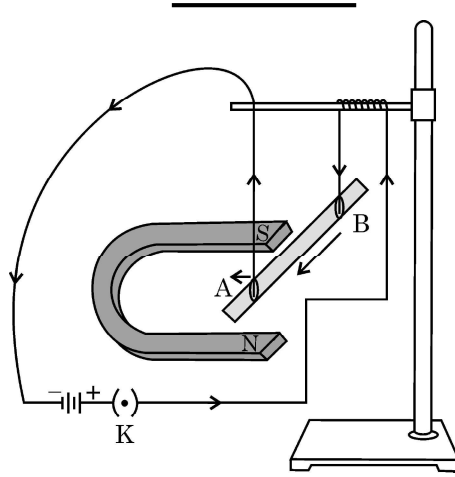

कारण देकर उल्लेख कीजिए कि :

- जब एल्युमिनियम की छड़ में उसके B सिरे से A सिरे की ओर विद्युत धारा प्रवाहित करते हैं, तो क्या देखते हैं ?
- उस स्थिति में क्या परिवर्तन देखते हैं जब छड़ 'AB' के अक्ष को चुम्बकीय क्षेत्र की दिशा में संरेखित करके छड़ में उसी दिशा में विद्युत धारा प्रवाहित करते हैं ?

अथवा

“चुम्बकीय क्षेत्र एक भौतिक राशि है जिसमें परिमाण और दिशा दोनों होते हैं।” किसी छड़ चुम्बक की चुम्बकीय क्षेत्र रेखाओं की सहायता से इस कथन को किस प्रकार सिद्ध किया जा सकता है ?

7. आधुनिक आवर्त नियम लिखिए। आधुनिक आवर्त सारणी में कितनी पंक्तियाँ और कितने स्तम्भ हैं ? 2

खण्ड – ख

8. अनुमंतांक 1100 W के विद्युत मोटर को 220 V के विद्युत मेन्स से संयोजित किया गया है। ज्ञात कीजिए : 3

- मेन्स से ली गयी विद्युत धारा
- यदि इसे 6 दिनों तक प्रतिदिन 5 घन्टे उपयोग किया जाता है, तो उपयुक्त विद्युत ऊर्जा

31/4/2

6



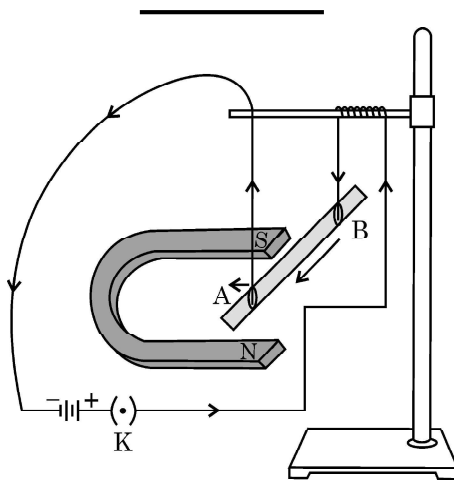

State giving reason :

- (a) What is observed when a current is passed through the aluminum rod from end B to end A ?
- (b) What change is observed in a situation in which the axis of the rod 'AB' is moved and aligned parallel to the magnetic field and current is passed in the rod in the same direction ?

OR

“Magnetic field is a physical quantity that has both direction and magnitude.” How can this statement be proved with the help of magnetic field lines of a bar magnet ?

7. State Modern Periodic Law. How many rows and columns are there in the Modern Periodic Table ? 2

SECTION - B

8. An electric motor rated 1100 W is connected to 220 V mains. Find : 3
 - (i) The current drawn from the mains,
 - (ii) Electric energy consumed if the motor is used for 5 hours daily for 6 days.

31/4/2

7



P.T.O.

(iii) यदि एक यूनिट का मूल्य ₹ 5 है, तो उपयुक्त ऊर्जा का कुल मूल्य

अथवा

नीचे दिए गए परिपथ का अध्ययन कीजिए और ज्ञात कीजिए :

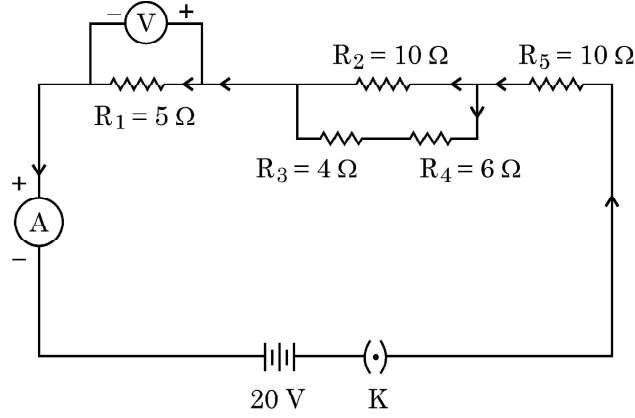

- (i) परिपथ का प्रभावी प्रतिरोध
- (ii) बैटरी से ली गयी विद्युत धारा
- (iii) 5Ω प्रतिरोधक के सिरोँ पर विभवान्तर

9. आपको एक प्रतिरोधक, एक कुंजी, एक अमीटर, एक वोल्टमीटर, चार 1.5 वोल्ट के सेल और कुछ संयोजक तार दिए गए हैं। इन परिपथ अवयवों का उपयोग करके आप ओह्म के नियम का अध्ययन करने के लिए नामांकित परिपथ आरेख खींचिए। प्रतिरोधक के सिरोँ पर विभवान्तर (V) और परिपथ से प्रवाहित विद्युत धारा (I) के बीच संबंध लिखिए तथा X-अक्ष के अनुदिश विभवान्तर को लेकर V-I ग्राफ भी खींचिए।

3

10. “कार्बन के दो विभिन्न रूपों – डायमण्ड (हीरे) और ग्रेफाइट की संरचनाएँ भिन्न हैं और उनके भौतिक गुणधर्म भी भिन्न हैं यद्यपि इनके रासायनिक गुणधर्म समान हैं।” ऐसा क्यों है, व्याख्या कीजिए।

3

अथवा

31/4/2

8



(iii) Total cost of energy consumed if the rate of one unit is ₹ 5.

OR

Study the following circuit and find :

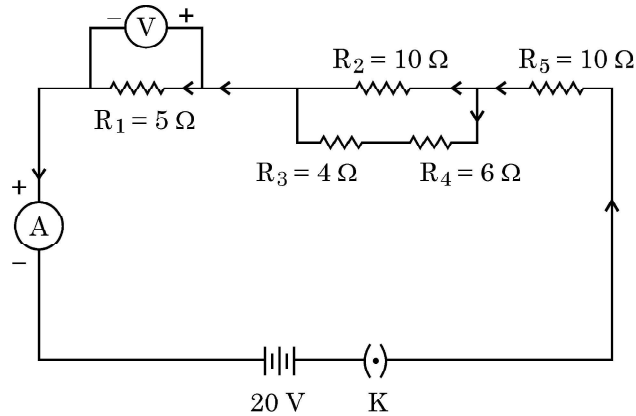

- (i) Effective resistance of the circuit
- (ii) Current drawn from the battery
- (iii) Potential difference across the $5\ \Omega$ resistor

9. You are provided with a resistor, a key, an ammeter, a voltmeter, four cells of $1.5\ \text{V}$ each and few connecting wires. Using these circuit components, draw a labelled circuit diagram to show the setup to study the Ohm's law.

State the relationship between potential difference (V) across the resistor and the current (I) flowing through it. Also draw V - I graph, taking V on the X -axis.

3

10. "Two different forms of carbon – diamond and graphite have different structures and very different physical properties even though their chemical properties are same." Explain why.

3

OR

31/4/2

9



P.T.O.

कारणों का उल्लेख कीजिए कि कार्बन क्यों

- (i) C^{4+} धनायन बनाने के लिए अपने चार इलेक्ट्रॉन क्यों नहीं खोता है और
(ii) C^{4-} ऋणायन बनाने के लिए चार इलेक्ट्रॉन क्यों ग्रहण नहीं करता है ?
कार्बन इस समस्या को यौगिकों को बनाने में किस प्रकार सुलझा लेता है ?
11. पुष्पी पादपों (पुष्प वाले पौधों) में परागण द्वारा परागकण वर्तिकाग्र तक स्थानान्तरित हो जाते हैं, परन्तु मादा युग्मक अण्डाशय में स्थित होते हैं। नामांकित आरेख (केवल संबंधित भागों का ही नामांकन) की सहायता से व्याख्या कीजिए कि नर युग्मक किस प्रकार अण्डाशय तक पहुँचता है। 3
12. उन तत्त्वों का नाम लिखिए जिनके यौगिक मेन्डेलीफ की आवर्त सारणी के वर्गीकरण के आधार थे। मेन्डेलीफ ने इन तत्त्वों को क्यों चुना ? इन तत्त्वों के यौगिकों के सूत्रों ने मेन्डेलीफ की उसकी सारणी में तत्त्व की स्थिति निर्धारित करने में किस प्रकार सहायता की ? 3
13. किसी पारितंत्र में सूर्य से आहार शृंखला के चार स्तरों तक ऊर्जा के प्रवाह को दर्शाने के लिए आरेख खींचिए। इस आरेख से निकाले जाने वाले दो निष्कर्षों की सूची बनाइए। 3

खण्ड – ग

इस खण्ड में 02 प्रकरण आधारित प्रश्न (14 और 15) हैं।

प्रत्येक प्रकरण के पश्चात् 03 उप-प्रश्न (a, b और c) दिए गए हैं।

भाग (a) और (b) अनिवार्य हैं। परन्तु भाग (c) में आंतरिक चयन प्रदान किया गया है।

14. AB अनेक फेरों वाली ताँबे के तार की कुण्डली है। आरेख में दर्शाए अनुसार इस कुण्डली के सिरे एक गैल्वेनोमीटर से संयोजित हैं। जब किसी प्रबल छड़ चुम्बक के उत्तर ध्रुव को कुण्डली के सिरे B की ओर लाया जाता है, तो गैल्वेनोमीटर में विक्षेपण का प्रेक्षण किया जाता है। 4

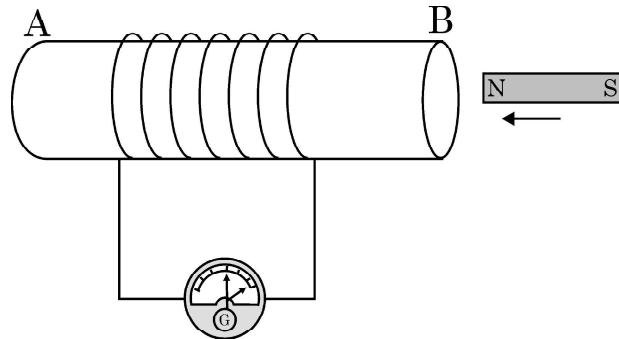

31/4/2

10



State the reasons, why carbon cannot

- (i) Lose four electrons to form C^{4+} cation, and
- (ii) Gain four electrons to form C^{4-} anion.

How does carbon overcome this problem to form compounds ?

11. In flowering plants, the pollen grains are transferred to stigma by pollination but the female germ cells are present in the ovary. Explain with the help of a labelled diagram (only concerned parts), how the male germ cell reaches the ovary. 3
12. Name the elements whose compounds formed the basis of classification in Mendeleev's periodic table. Why did Mendeleev choose these elements ? 3
How the formulae of these compounds had helped Mendeleev in deciding the position of an element in his periodic table ?
13. Draw a diagram showing flow of energy from solar input to a food chain having four trophic levels in an eco system. List two inferences that can be drawn from the energy flow diagram. 3

SECTION - C

This section has 02 case based questions (14 and 15).

Each case is followed by **03** sub-questions (a, b and c).

Part (a) and (b) are compulsory. However an internal choice has been provided in Part (c).

14. AB is a coil of copper wire having a large number of turns. The ends of the coil are connected with a galvanometer as shown. When the north pole of a strong bar magnet is moved towards the end B of the coil, a deflection is observed in the galvanometer. 4

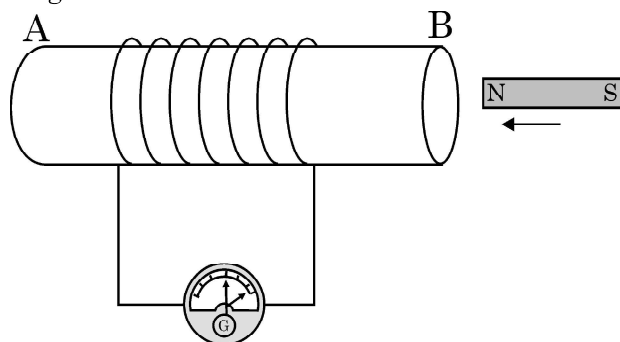

31/4/2

11



P.T.O.



- (a) इस क्रियाकलाप में गैल्वेनोमीटर का उपयोग करने का कारण लिखिए तथा उल्लेख कीजिए कि चुम्बक को कुण्डली की ओर लाने पर सूई में क्षणिक विक्षेपण क्यों आता है ।
- (b) गैल्वेनोमीटर में विक्षेपण तब भी होता है जब चुम्बक को स्थिर रखकर कुण्डली को चुम्बक के दक्षिण ध्रुव की ओर ले जाया जाता है । क्यों ?
- (c) इस क्रियाकलाप द्वारा निकाला जा सकने वाला निष्कर्ष लिखिए ।

क्या गैल्वेनोमीटर के क्षणिक विक्षेपण में कोई अन्तर आयेगा यदि कुण्डली में फेरों की संख्या में वृद्धि कर दी जाए तथा और अधिक प्रबलता के चुम्बक को कुण्डली की ओर लाया जाए ?

अथवा

विद्युत चुम्बकीय प्रेरण किसे कहते हैं ? उस स्थिति में गैल्वेनोमीटर में क्या प्रेक्षण किया जाता है जब किसी प्रबल छड़ चुम्बक को अत्यधिक फेरों वाली कुण्डली के एक सिरे के निकट विराम की स्थिति में रखा जाता है ? अपने उत्तर की पुष्टि कीजिए ।

15. विभिन्न स्पीशीज़ में किसी एकल जीव का लिंग निर्धारण भिन्न-भिन्न कारकों द्वारा होता है । कुछ जन्तु पूर्ण रूप से पर्यावरण पर निर्भर करते हैं, जबकि कुछ अन्य जन्तु अपना लिंग, अपने जीवन काल में बदल सकते हैं । इससे यह इंगित होता है कि कुछ स्पीशीज़ का लिंग निर्धारण आनुवंशिक नहीं है । लेकिन मानव में लिंग निर्धारण आनुवंशिक आधार पर होता है ।

4

- (a) लिंग गुणसूत्र 'X' और 'Y' किस प्रकार साइज़ में एक दूसरे से भिन्न होते हैं ? मानवों में लिंग गुणसूत्र के उस जोड़े का नाम लिखिए जो परिपूर्ण जोड़ा नहीं होता ।

31/4/2

12



-
- (a) State the reason for using galvanometer in the activity and why does its needle deflects momentarily when magnet is moved towards the coil.
- (b) A deflection in the galvanometer is also observed when the magnet is held stationary and the coil is moved towards the south of pole of the magnet. Why ?
- (c) State the conclusion that can be drawn from this activity.

Will there be any change in the momentary deflection in the galvanometer if number of turns in the coil is increased and a more stronger magnet is moved towards the coil ?

OR

What is electromagnetic induction ? What is observed in the galvanometer when a strong bar magnet is held stationary near one end of a coil of large number of turns ? Justify your answer.

15. Sex of an individual is determined by different factors in various species. Some animals rely entirely on the environmental cues, while in some other animals the individuals can change their sex during their life time indicating that sex of some species is not genetically determined. However, in human beings, the sex of an individual is largely determined genetically.

4

- (a) In what way are the sex chromosomes 'X' and 'Y' different in size ? Name the mismatched pair of sex chromosome in humans.

31/4/2

13



P.T.O.



-
- (b) लिंग गुणसूत्रों के अतिरिक्त मानवों में उपस्थित अन्य गुणसूत्रों की संख्या लिखिए । किस जनक में लिंग सूत्रों का परिपूर्ण जोड़ा नहीं होता है ?
- (c) दो उदाहरण देते हुए इस कथन की पुष्टि कीजिए कि “लिंग निर्धारण सदैव ही आनुवंशिक आधार पर नहीं होता है ।”

अथवा

यह दर्शाने के लिए प्रवाह आरेख खींचिए कि मानवों में लिंग निर्धारण आनुवंशिक आधार पर होता है ।

31/4/2

14



-
- (b) Write the number of chromosomes present in human beings apart from sex chromosomes. Which of the parent has a mismatched pair of sex chromosomes ?
- (c) Citing two examples, justify the statement “Sex of an individual is not always determined genetically”.

OR

Draw a flow chart to show that sex is determined genetically in human beings.

31/4/2

15



*

31/4/2

136 B

16



Strictly Confidential: (For Internal and Restricted use only)
Class : X Secondary School Term II Examination, 2022
Marking Scheme – Science SUBJECT CODE -086
[Paper Code : 31/4/2]

General Instructions: -

1. You are aware that evaluation is the most important process in the actual and correct assessment of the candidates. A small mistake in evaluation may lead to serious problems which may affect the future of the candidates, education system and teaching profession. To avoid mistakes, it is requested that before starting evaluation, you must read and understand the spot evaluation guidelines carefully.
2. **“Evaluation policy is a confidential policy as it is related to the confidentiality of the examinations conducted, Evaluation done and several other aspects. Its’ leakage to public in any manner could lead to derailment of the examination system and affect the life and future of millions of candidates. Sharing this policy/document to anyone, publishing in any magazine and printing in News Paper/Website etc may invite action under IPC.”**
3. Evaluation is to be done as per instructions provided in the Marking Scheme. It should not be done according to one’s own interpretation or any other consideration. Marking Scheme should be strictly adhered to and religiously followed. **However, while evaluating, answers which are based on latest information or knowledge and/or are innovative, they may be assessed for their correctness otherwise and marks be awarded to them. In class-X, while evaluating two competency based questions, please try to understand given answer and even if reply is not from marking scheme but correct competency is enumerated by the candidate, marks should be awarded.**
4. The Head-Examiner must go through the first five answer books evaluated by each evaluator on the first day, to ensure that evaluation has been carried out as per the instructions given in the Marking Scheme. The remaining answer books meant for evaluation shall be given only after ensuring that there is no significant variation in the marking of individual evaluators.
5. Evaluators will mark(✓) wherever answer is correct. For wrong answer ‘X’ be marked. Evaluators will not put right kind of mark while evaluating which gives an impression that answer is correct and no marks are awarded. **This is most common mistake which evaluators are committing.**
6. If a question has parts, please award marks on the right-hand side for each part. Marks awarded for different parts of the question should then be totaled up and written in the left-hand margin and encircled. This may be followed strictly.
7. If a question does not have any parts, marks must be awarded in the left-hand margin and encircled. This may also be followed strictly.
8. If a student has attempted an extra question, answer of the question deserving more marks should be retained and the other answer scored out.
9. No marks to be deducted for the cumulative effect of an error. It should be penalized only once.
10. A full scale of marks **40** has to be used. Please do not hesitate to award full marks if the answer deserves it.
11. Every examiner has to necessarily do evaluation work for full working hours i.e. 8 hours every day and evaluate 30 answer books per day in main subjects and 35 answer books per day in other subjects (Details are given in Spot Guidelines). This is in view of the reduced syllabus and number of questions in question paper.

12. Ensure that you do not make the following common types of errors committed by the Examiner in the past:-
- Leaving answer or part thereof unassessed in an answer book.
 - Giving more marks for an answer than assigned to it.
 - Wrong totalling of marks awarded on a reply.
 - Wrong transfer of marks from the inside pages of the answer book to the title page.
 - Wrong question wise totalling on the title page.
 - Wrong totalling of marks of the two columns on the title page.
 - Wrong grand total.
 - Marks in words and figures not tallying.
 - Wrong transfer of marks from the answer book to online award list.
 - Answers marked as correct, but marks not awarded. (Ensure that the right tick mark is correctly and clearly indicated. It should merely be a line. Same is with the X for incorrect answer.)
 - Half or a part of answer marked correct and the rest as wrong, but no marks awarded.
13. While evaluating the answer books if the answer is found to be totally incorrect, it should be marked as cross (X) and awarded zero (0)Marks.
14. Any unassessed portion, non-carrying over of marks to the title page, or totaling error detected by the candidate shall damage the prestige of all the personnel engaged in the evaluation work as also of the Board. Hence, in order to uphold the prestige of all concerned, it is again reiterated that the instructions be followed meticulously and judiciously.
15. The Examiners should acquaint themselves with the guidelines given in the Guidelines for spot Evaluation before starting the actual evaluation.
16. Every Examiner shall also ensure that all the answers are evaluated, marks carried over to the title page, correctly totaled and written in figures and words.
17. The Board permits candidates to obtain photocopy of the Answer Book on request in an RTI application and also separately as a part of the re-evaluation process on payment of the processing charges.



MARKING SCHEME
SECONDARY SCHOOL EXAMINATION TERM-II, 2022
SUBJECT : SCIENCE CODE – 086
[PAPER CODE : 31/4/2]

Instructions:-

- The marking scheme carries only suggested value points for the answers.
- These are only guidelines and do not constitute the complete answer.
- The students can have their own expression and if the expression is correct, the marks are awarded accordingly.

Maximum Marks : 40

Q. No.	EXPECTED ANSWER / VALUE POINTS	Marks	Total Marks						
	SECTION—A								
1.	(a) Placenta—Helps in the transportation of glucose and oxygen from the mother to the embryo/ removal of waste (b) Egg is carried from the ovary to uterus/ site of fertilisation (c) Helps in the development of embryo/ implantation (d) Production of female gamete or ovum/secretion of female sex hormone	$\frac{1}{2}$ $\frac{1}{2}$ $\frac{1}{2}$ $\frac{1}{2}$	2						
2.	<ul style="list-style-type: none"> • The plants have genes that have information to produce enzyme for growth, a lot of hormone is produced, a plant will be tall. • If the gene for that enzyme has an alteration that makes the enzyme less efficient, the amount of hormone produced will be less and a plant will be short. <p style="text-align: center;">OR</p> <div style="display: flex; align-items: center; justify-content: center;"> <div style="margin-right: 20px;">F₁</div> <div style="text-align: center;"> <p>Red Red</p> <p>Rr X Rr</p> <p> ↓ </p> <table border="1" style="border-collapse: collapse; text-align: center;"> <tr> <td style="padding: 5px;">R</td> <td style="padding: 5px;">RR</td> <td style="padding: 5px;">Rr</td> </tr> <tr> <td style="padding: 5px;">r</td> <td style="padding: 5px;">Rr</td> <td style="padding: 5px;">rr</td> </tr> </table> </div> </div> <p>75%—Red (RR and Rr) flowers 25%—White flowers (rr)</p> <p>OR</p> <p>Ratio—3 : 1 Red : White</p>	R	RR	Rr	r	Rr	rr	1 1 1/2 1/2 1/2 1/2 1/2 1/2	2
R	RR	Rr							
r	Rr	rr							



3.	(a) CH ₃ OH (b) C ₃ H ₄ (c) HCOOH (d) C _n H _{2n}	½ ½ ½ ½	2
4.	<ul style="list-style-type: none"> Improvement in lifestyle has led to large consumption of resources Demand for things with disposable nature increases the non-biodegradable wastes like plastics, metal cans etc. <p style="text-align: right;">(or any other)</p> <p style="text-align: center;">OR</p>	1 1	2
4.	<ul style="list-style-type: none"> The demand for increasing the shelf life of products and transporting goods over large distances is increasing, so the plastics / polyethene packing is preferred. Less use of biodegradable products such as paper bag, cloth bag etc. <p style="text-align: right;">(or any other)</p>	1 1	
5.	<ul style="list-style-type: none"> The process in which an individual is cut or broken up into many pieces and many of these pieces grow into separate individual. In Planaria regeneration is carried out by specialised cells, these cells proliferate, develop and differentiate into various cell types and tissues. <p>(explanation with diagram will be awarded full marks.)</p>	1 1	2
6.	(a) <ul style="list-style-type: none"> Rod AB would get displaced Reason: When a current carrying conductor is placed in an external magnetic field perpendicularly, it experiences a force. 	½ ½	2
6.	(b) As current and magnetic field are parallel, there will be no force experienced by the conductor hence no displacement in rod. <p style="text-align: center;">OR</p> <ul style="list-style-type: none"> Field lines emerge from the north pole and merge at south pole/the direction in which a north pole of the compass needle moves inside it. The relative strength of the magnetic field is shown by the degree of closeness of the field lines. Crowded are the field lines, stronger is the field. <p>Or diagrammatic expression.</p>	1 1	

			2
7.	<p>Properties of elements are a periodic function of their atomic number</p> <p>‘18’ vertical columns called groups</p> <p>‘7’ horizontal rows are known as periods</p>	<p>1</p> <p>½</p> <p>½</p>	2
SECTION—B			
8.	<p>Power (P) = 1100 W, V = 220 V</p> <p>(i) Current drawn $= I = \frac{P}{V}$</p> $= \frac{1100 \text{ W}}{220 \text{ V}} = 5 \text{ A}$ <p>(ii) $E = P \times t$</p> $= 1100 \text{ W} \times 5 \text{ h} \times 6 = 33000 \text{ Wh}$ <p>(iii) Cost of one commercial unit = ₹ 5</p> <p>Energy consumed = 33 kWh = 33 unit = $118.8 \times 10^6 \text{ J}$</p> <p>Cost of 33 unit = $33 \times 5 = ₹ 165$</p> <p style="text-align: center;">OR</p> <p>(i) Effective resistance of the circuit</p> $R_s = R_3 + R_4 = 4\Omega + 6\Omega = 10\Omega$ $\frac{1}{R_p} = \frac{1}{R_s} + \frac{1}{R_2} = \frac{1}{10\Omega} + \frac{1}{10\Omega} = \frac{2}{10\Omega} = \frac{1}{5\Omega}$ $R_p = 5\Omega$ <p>Total resistance of the circuit = $R_1 + R_p + R_5 = 5 + 5 + 10 = 20\Omega$</p>	<p>½</p> <p>½</p> <p>½</p> <p>½</p> <p>½</p> <p>½</p> <p>½</p>	

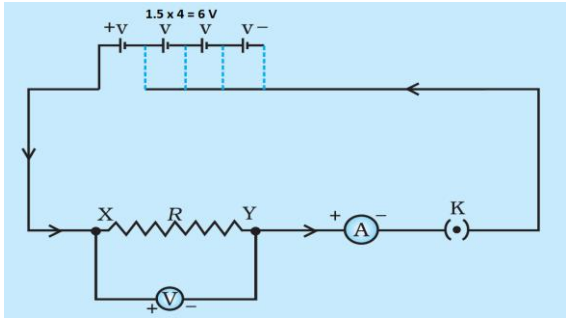
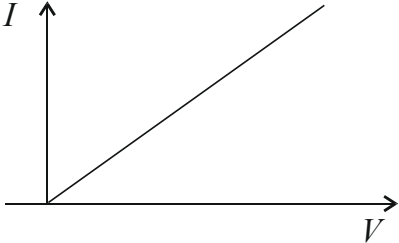
	<p>(ii) Current drawn from the battery</p> $V = 20V, R = 20\Omega$ $I = \frac{V}{R} = \frac{20V}{20\Omega}$ $I = 1 A$ <p>(iii) Reading in voltmeter connected across 5Ω Resistance</p> $V = IR$ $I = 1 A$ $R = 5\Omega$ $V = 1 A \times 5\Omega = 5 V$	<p>$\frac{1}{2}$</p> <p>$\frac{1}{2}$</p> <p>$\frac{1}{2}$</p> <p>$\frac{1}{2}$</p>	<p>3</p>
<p>9.</p>	<p>Electric circuit</p>  <p>Diagram making Any two labelling Potential difference (V) directly proportional to the current (I).</p> 	<p>1</p> <p>$\frac{1}{2}, \frac{1}{2}$</p> <p>$\frac{1}{2}$</p> <p>$\frac{1}{2}$</p>	<p>3</p>
<p>10.</p>	<ul style="list-style-type: none"> In diamond, each carbon atom is bonded to four other carbon atoms forming a rigid three dimensional structure. This makes diamond the hardest substance known. 	<p>1</p>	

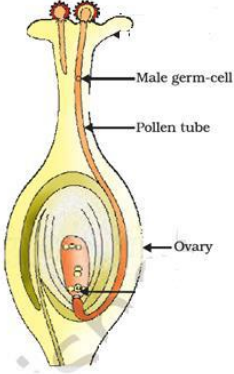

10.	<ul style="list-style-type: none"> In graphite, each carbon atom is bonded to three other carbon atoms in same plane giving a hexagonal array being placed in layers one above the other this makes graphite a smooth and slippery substance. Both diamond and graphite are composed of carbon, therefore their chemical properties are same. / Both are allotropic form of Carbon. <p style="text-align: center;">OR</p> <p>(i) If carbon atom loses four electrons forming C^{4+} cation, it would require a large amount of energy to remove four electrons leaving behind a carbon cation with six protons in its nucleus holding two electrons.</p> <p>(ii) If carbon atom gains four electrons forming C^{4-} anion, it would be difficult for a nucleus with six protons to hold on ten electrons, that is four extra electrons.</p> <ul style="list-style-type: none"> Carbon atom overcomes this problem by sharing its valence electrons with other atoms of carbon or with atoms of other elements. 	1 1 1 1	3
11.	<p>After the pollen lands on a suitable stigma, it has to reach the female germ cells which is located in the ovary. For this a tube grows out of the pollen grain and travels through the style to reach the ovary.</p> <div style="text-align: center;">  <p style="text-align: center;">Germination of pollen on stigma</p> <p>Labelling: pollen tube/ ovary/ male germ cell (any two labelling)</p> </div>	1 1 $\frac{1}{2}$, $\frac{1}{2}$	3
12.	<ul style="list-style-type: none"> Hydrogen and Oxygen He selected hydrogen and oxygen as they are very reactive and formed compound with most of the elements. The formulae of hydrides and oxides formed by an element were treated as one of the basic properties of an element for its classification. 	1 1 1	3

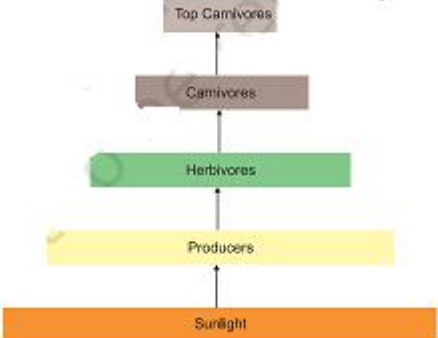

<p>13. Diagram</p>	<div style="text-align: center;">  </div> <p>(Can be shown with the help of food chain starting from sun)</p> <p><i>Inferences:</i></p> <ul style="list-style-type: none"> • Flow of energy is unidirectional • Sun is the ultimate source of energy. • Energy available at each trophic level gets diminished progressively due to loss of energy at each level. • Every food chain starts with producers. <p style="text-align: right;">(Or any other inference) (any two)</p>	<p style="text-align: center;">1</p> <p style="text-align: center;">1,1</p>	<p style="text-align: center;">3</p>
SECTION—C			
<p>14.</p>	<p>(a)</p> <ul style="list-style-type: none"> • Galvanometer is used to detect the presence of current along with its direction. • Needle deflects momentarily due to momentary change in magnetic field associated with the coil due to which current induces. <p>(b) When coil moves towards the magnet, the magnetic field passing through coil changes and a current is induced in the coil due to which deflection is observed in galvanometer.</p> <p>(c)</p> <ul style="list-style-type: none"> • The relative motion of a magnet and coil produces an induced potential difference which sets up an induced current in the circuit and it lasts so long the relative motion is there. • Momentary deflection will be there with increased magnitude. <p style="text-align: center;">OR</p> <ul style="list-style-type: none"> • It is a process by which a changing magnetic field in a conductor induces current in another conductor. 	<p style="text-align: center;">½</p> <p style="text-align: center;">½</p> <p style="text-align: center;">1</p> <p style="text-align: center;">1</p> <p style="text-align: center;">1</p> <p style="text-align: center;">1</p>	

	<ul style="list-style-type: none"> No deflection in galvanometer <p>As there is no relative motion between the coil and magnet which leads to no change in magnetic field associated with coil hence no induced current generates.</p>	$\frac{1}{2}, \frac{1}{2}$	4																				
15.	<p>(a)</p> <ul style="list-style-type: none"> X chromosome is of normal size and Y chromosome is short / Y chromosome is shorter than X chromosome. XY pair of chromosomes <p>(b) 44 chromosomes or 22 pairs of chromosomes, male / father</p> <p>(c)</p> <ul style="list-style-type: none"> In reptiles, the temperature at which fertilized eggs are kept determines whether the animals developing in the eggs would be a male or a female. In snails, they can change their sex during their lifetime. <p style="text-align: center;">OR</p> <table style="width: 100%; border-collapse: collapse;"> <tr> <td style="width: 15%;">Parents</td> <td style="width: 20%; text-align: center;">XY Male</td> <td style="width: 20%;"></td> <td style="width: 20%; text-align: center;">XX Female</td> <td style="width: 25%;"></td> </tr> <tr> <td>Gametes</td> <td style="text-align: center;">X Y</td> <td></td> <td style="text-align: center;">X</td> <td></td> </tr> <tr> <td>Zygote</td> <td style="text-align: center;">XX</td> <td style="text-align: center;">XY</td> <td></td> <td></td> </tr> <tr> <td>Offsprings</td> <td style="text-align: center;">↓ Female</td> <td></td> <td style="text-align: center;">↓ Male</td> <td></td> </tr> </table>	Parents	XY Male		XX Female		Gametes	X Y		X		Zygote	XX	XY			Offsprings	↓ Female		↓ Male		$\frac{1}{2}$ $\frac{1}{2}$ $\frac{1}{2}$ $\frac{1}{2}$ 1 1 $\frac{1}{2} \times 4$	4
Parents	XY Male		XX Female																				
Gametes	X Y		X																				
Zygote	XX	XY																					
Offsprings	↓ Female		↓ Male																				

* * *